

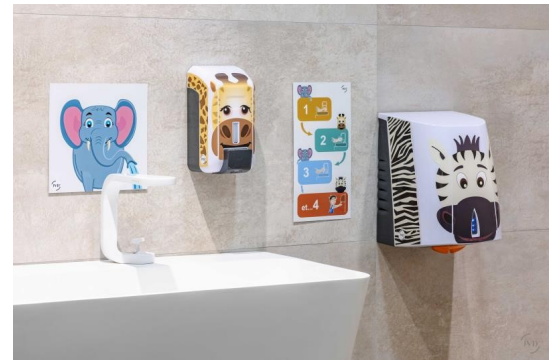

8111056KIDS

## SUP'AIR Kids white (including Cleanline Gel Kids)

including a SUP'AIR KIDS white hand dryer, a Cleanline Kids Gel soap dispenser and pedagogical plates to assist children when washing their hands.



### PRODUCT PLUSES

- Ultra-fast drying
- Very low energy consumption
- Compact
- Excellent quality-price ratio
- Can easily replace an existing hand dryer

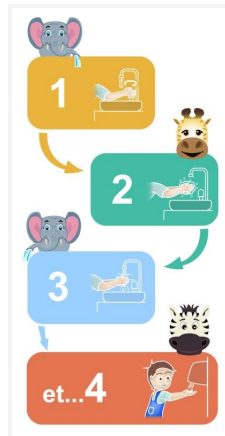
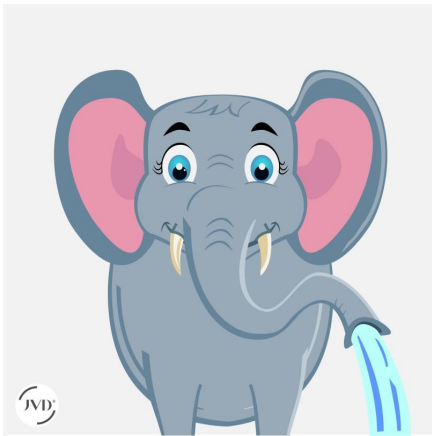

### ECO-FRIENDLY

- Low power consumption
- 25% recycled plastic
- 75% less carbon emissions compared to paper
- 1 hygiene kit sent to the Philippines via Better With Water association



10 YEARS REPAIRABLE

MADE IN FRANCE

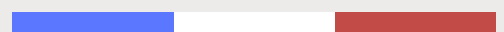

# 8111056KIDS

## SUP'AIR Kids white (including Cleanline Gel Kids)

### SPECIFICATIONS

Material	ABS
Colour	Kids
Drying time (s)	10-15s
Sound level (dB) (1m in front of the appliance)	75
Outlet air speed (m/s)	90
Air flow rate (m³/h)	130
Air outlet temperature (°C)	40
Safety in case of malfunction	Yes
Filter	Anti-bacterial filter (Option)
Vandal-safe	Yes
Drying zone lighting	Yes

### ELECTRICAL

Rated Power (W)	600
Voltage	220-240V
Frequency (Hz)	50
Standby power consumption (W)	2.2
Detection type	Infrared
Motor speed (rpm)	24000
Type of motor	Brushed AC
Motor lifetime (number of operations)	350000

### DIMENSIONS

Height (mm)	292
Width (mm)	216
Depth (mm)	195
Weight (kg)	3.42

### BOX DIMENSIONS

Height (mm)	295
Width (mm)	240
Depth (mm)	205
Weight (kg)	3.73

### TECHNICAL DRAWING

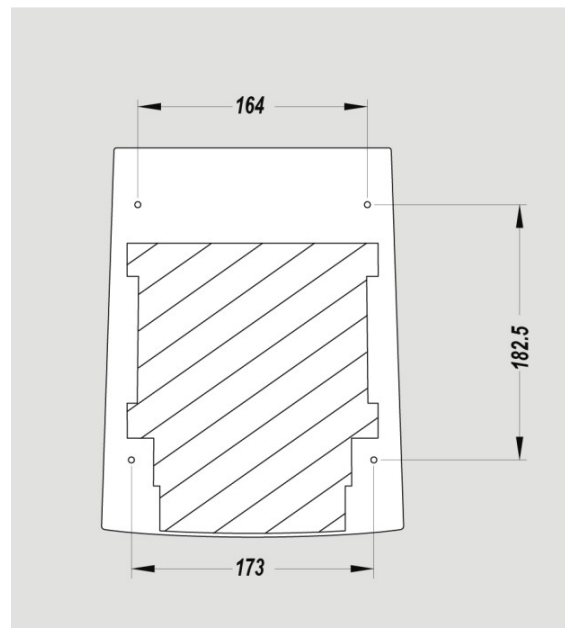
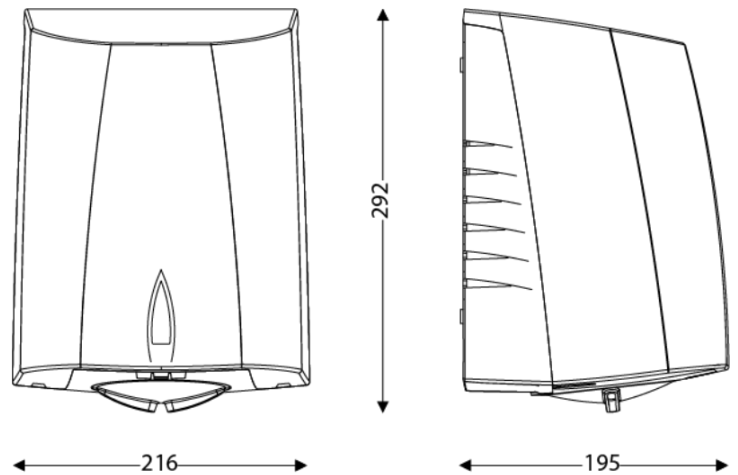

### RECOMMENDED INSTALLATION HEIGHTS

- Men installation height (cm) : 130
- Women installation height (cm) : 125
- Children installation height (cm) : 120
- Disabled person installation height (cm) : 100

