



Shield[®]

COMPACT

Personal air purifier made in France,
effective against all nuisances present
in the air.

+ ADVANTAGES

- A unique technology
- A compact design
- Eco-designed

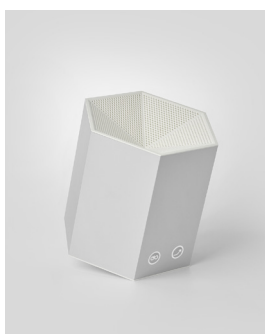

Cream white
REF. 8 77 2134-WH

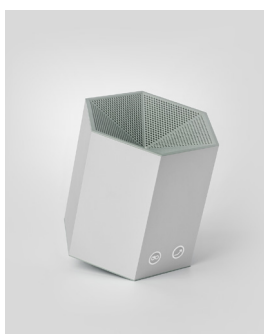

Malachite green
REF. 8 77 2134-GR



Sapphire blue
REF. 8 77 2134-BL



Matte black
REF. 8 77 2134-BK

100% OF NUISANCES ERADICATED



CONTAMINANTS



POLLUTANTS



ODORS



ALLERGENS

DESIGNED BY **RF Studio**



SPECIFICATIONS

- Power supply: 230VAC / 12VDC
- Adapter supplied
- Power output: JACK
- Power: 22 W
- Electrical insulation: Class III
- Cover material: Anodised aluminium
- Total protection sphere: personal bubble
- Treatment area: up to 20 m²
- 2 operating modes: CONTINUOUS / BOOST
- Filter change (REF. 5 90 2948) notified by a red LED after 4000 hours of use
- Weight: 805 gr



MODES

CONTINUOUS mode: Activate this mode to treat your personal sphere continuously.

BOOST mode: In case of unusual events (high odours, contamination or pollution risks), activate this mode to treat your personal environment intensively.



ACCESSORIES

WALL MOUNTED SUPPORT
REF. 2 90 3068

- Designed by RF Studio
- Eco-design and made in France
- Anti-theft retention and security

ANTI-THEFT
REF. 2 10 2097

- Discretion
- Ease of installation

DIMENSIONS

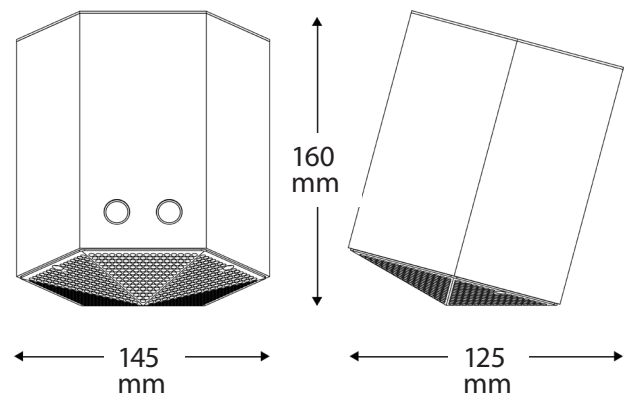

IDEAL POSITIONING

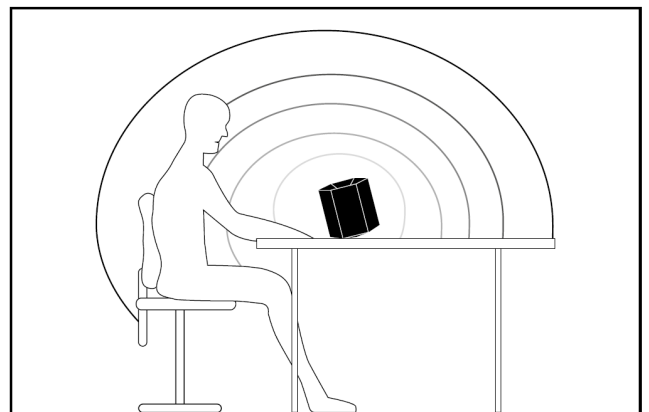

Wall-mounted version:

